

Pusher Attachment (F-Style)

All pusher attachments are molded 6 in (152.4 mm) wide and can be cut down to a minimum height of 1/4 in (6.35 mm).

The F3 designation represents an F-style pusher attachment at a height of 3 in (76.2 mm).

Please indicate if pusher attachments are required every pitch, every second pitch, etc. when ordering. Also, indicate if indents are required in the center, on one or both sides of the chain.

For example, "I would like F3 pusher attachments every 8th pitch indented 3/4 in on both sides of the chain."

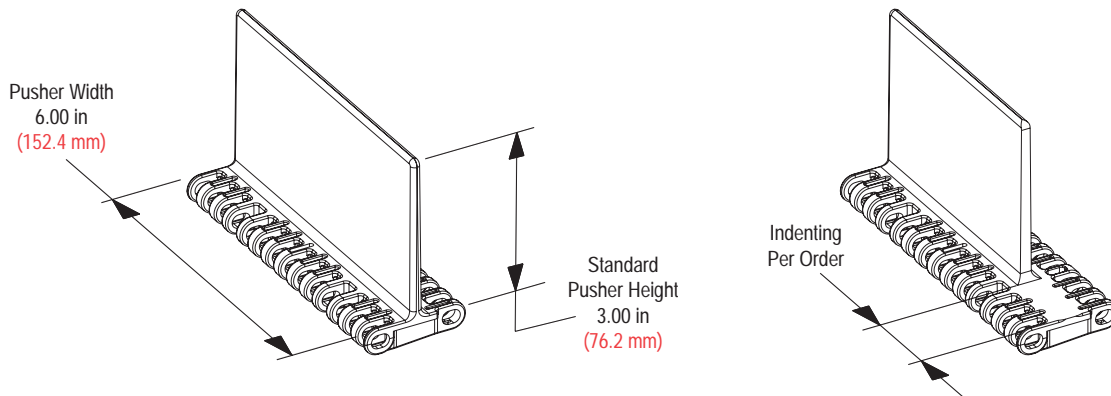

Pusher Attachment (Ribbed)

All pusher attachments are molded 6 in (152.4 mm) wide and can be cut down to a minimum height of 1/4 in (6.35 mm).

The F6 designation represents an F-style pusher attachment at a height of 6 in (152.4 mm).

Please indicate if pusher attachments are required every pitch, every second pitch, etc. when ordering. Also, indicate if indents are required in the center, on one or both sides of the chain.

For example, "I would like F6 pusher attachments every 8th pitch indented 3/4 in on both sides of the chain."

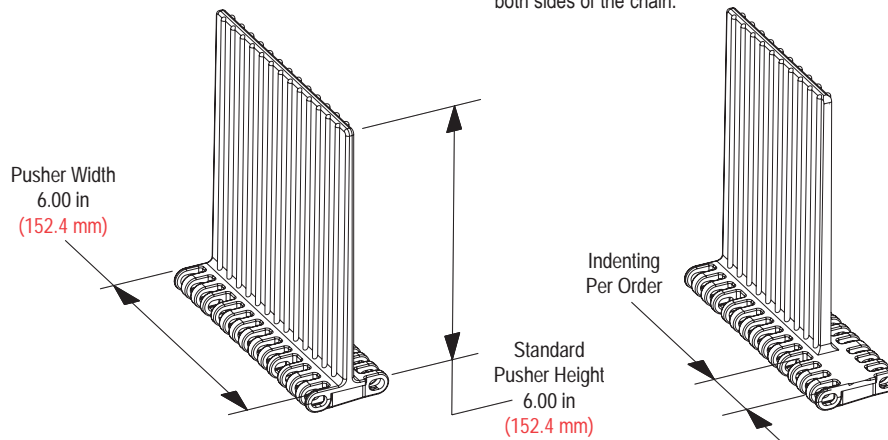

Sideguard Attachment

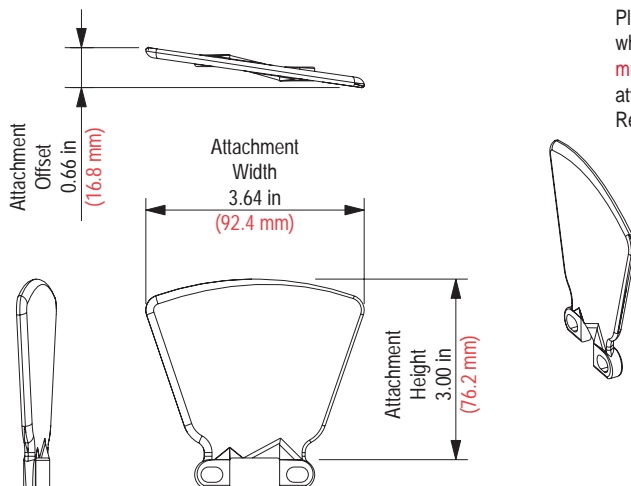

Please indicate if sideguard attachments are required down one or both sides of the chain when ordering. Sideguard attachments can be cut down to a minimum height of 1 in (25.4 mm). If the chain is ordered with both sideguard and pusher attachments, the sideguard attachment will be furnished the **same height** as the pusher attachment. Please contact Rexnord Industries, LLC. if any deviations from this standard are required.

