



Stainless Steel 316 One-touch Fittings

- Material
Metal parts: **Stainless steel 316**
Seal parts: **Special FKM**
- Can be used with steam
- Operating fluid temperature
-5 to 150°C
- Grease-free



- Applicable tubing material
• FEP, PFA, Nylon, Soft nylon, Polyurethane
• Polyolefin

All stainless steel 316 except seal parts

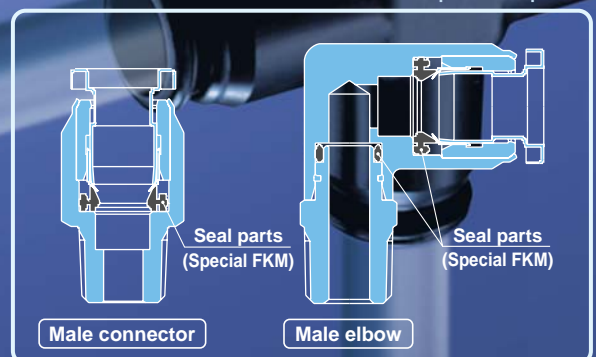

Male Connector

Applicable tubing O.D. (mm)	Connection thread	Model
ø4	M5	KQGH04-M5
	R1/8	KQGH04-01S
ø6	M5	KQGH06-M5
	R1/8	KQGH06-01S
	R1/4	KQGH06-02S
ø8	R1/8	KQGH08-01S
	R1/4	KQGH08-02S
	R3/8	KQGH08-03S
ø10	R1/4	KQGH10-02S
	R3/8	KQGH10-03S
ø12	R3/8	KQGH12-03S
	R1/2	KQGH12-04S



Hexagon Socket Head Male Connector

Applicable tubing O.D. (mm)	Connection thread	Model
ø4	M5	KQGS04-M5
	R1/8	KQGS04-01S
ø6	M5	KQGS06-M5
	R1/8	KQGS06-01S
	R1/4	KQGS06-02S
ø8	R1/8	KQGS08-01S
	R1/4	KQGS08-02S
	R3/8	KQGS08-03S
ø10	R1/4	KQGS10-02S
	R3/8	KQGS10-03S
ø12	R3/8	KQGS12-03S
	R1/2	KQGS12-04S



Straight Union

Applicable tubing O.D. (mm)	Model
ø4	KQGH04-00
ø6	KQGH06-00
ø8	KQGH08-00
ø10	KQGH10-00
ø12	KQGH12-00



Male Elbow

Applicable tubing O.D. (mm)	Connection thread	Model
ø4	M5	KQGL04-M5
	R1/8	KQGL04-01S
ø6	M5	KQGL06-M5
	R1/8	KQGL06-01S
	R1/4	KQGL06-02S
ø8	R1/8	KQGL08-01S
	R1/4	KQGL08-02S
	R3/8	KQGL08-03S
ø10	R1/4	KQGL10-02S
	R3/8	KQGL10-03S
ø12	R3/8	KQGL12-03S
	R1/2	KQGL12-04S



Union Elbow

Applicable tubing O.D. (mm)	Model
ø4	KQGL04-00
ø6	KQGL06-00
ø8	KQGL08-00
ø10	KQGL10-00
ø12	KQGL12-00



Male Branch Tee

Applicable tubing O.D. (mm)	Connection thread	Model
ø4	M5	KQGT04-M5
	R1/8	KQGT04-01S
ø6	M5	KQGT06-M5
	R1/8	KQGT06-01S
	R1/4	KQGT06-02S
ø8	R1/8	KQGT08-01S
	R1/4	KQGT08-02S
	R3/8	KQGT08-03S
ø10	R1/4	KQGT10-02S
	R3/8	KQGT10-03S
ø12	R3/8	KQGT12-03S
	R1/2	KQGT12-04S



Union Tee

Applicable tubing O.D. (mm)	Model
ø4	KQGT04-00
ø6	KQGT06-00
ø8	KQGT08-00
ø10	KQGT10-00
ø12	KQGT12-00



Union "Y"

Applicable tubing O.D. (mm)	Model
ø4	KQGU04-00
ø6	KQGU06-00
ø8	KQGU08-00
ø10	KQGU10-00
ø12	KQGU12-00



Bulkhead Union

Applicable tubing O.D. (mm)	Model
ø4	KQGE04-00
ø6	KQGE06-00
ø8	KQGE08-00
ø10	KQGE10-00
ø12	KQGE12-00



Stainless Steel 316

One-touch Fittings

Series KQG

Applicable Tubing

Tube material	FEP, PFA, Nylon, Soft nylon, Polyurethane, Polyolefin ^{Note 3)}
Tube O.D.	ø4, ø6, ø8, ø10, ø12

Specifications

Operating fluid	Air, Water, Steam ^{Note 4)}
Operating pressure range ^{Note 1)}	-100 kPa to 1MPa
Proof pressure	3.0 MPa
Ambient and Operating fluid temperature ^{Note 2)}	-5 to 150°C (No freezing)
Lubricant	Grease-free specification
Seal on the threads	With sealant

Note 1) Please avoid using in a vacuum holding application such as leak tester, since there is leakage.
 Note 2) When using at 100°C or higher, or an extended period of time, we recommend that an inner sleeve is used.

Note 3) In the event of using polyurethane tubing, we recommend the use of an inner sleeve in cases where the tubing is strained.

Note 4) Special FKM that is resistant even when steam is used.

Tube size	Tubing model (Material)				Applicable inner sleeve	
	TU (Polyurethane)	TUS (Soft polyurethane)	TH (FEP)	TL (PFA)	Model	Length
0402	—	—	●	—	TJ-0402	18
0425	●	●	●	—	TJ-0425	18
0403	—	—	—	●	TJ-0403	18
0604	●	●	●	●	TJ-0604	19
0805	●	●	—	—	TJ-0805	20.5
0806	—	—	●	●	TJ-0806	20.5
1065	●	●	—	—	TJ-1065	23
1075	—	—	●	—	TJ-1075	23
1008	—	—	●	●	TJ-1208	24
1208	●	●	—	—		
1209	—	—	●	—	TJ-1209	24
1210	—	—	●	●	TJ-1210	24

Construction

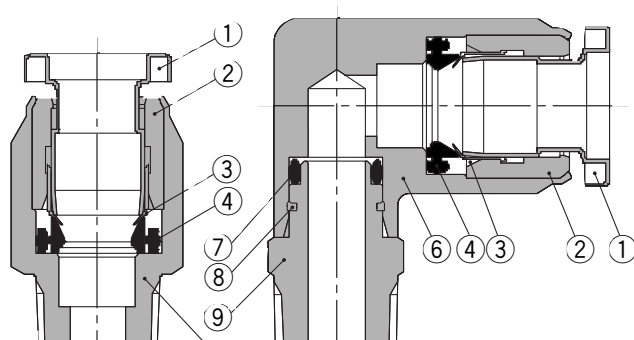

No.	Description	Material
1	Release bushing	Stainless steel 316
2	Guide	Stainless steel 316
3	Chuck	Stainless steel 316
4	Seal	Special FKM
5	Male connector body	Stainless steel 316
6	Male elbow body	Stainless steel 316
7	O-ring	Special FKM

Series KQG

Dimensions

Male Connector KQGH



Applicable tubing O.D. (mm)	Connection thread R	Model	H (width across flats)	øD	L	A*	M	Effective area (mm ²) ^{Note 1)}	Weight (g)
ø4	M5	KQGH04-M5	10	10	22.3	19.3	18	4	7.4
	1/8	KQGH04-01S			24	20		5.6	8.4
ø6	M5	KQGH06-M5	12	12	24.1	21.1	18.8	4	11
	1/8	KQGH06-01S			24.3	20.3		10.4	11
	1/4	KQGH06-02S			25.8	19.8		18	18
ø8	1/8	KQGH08-01S	14	14	30.5	26.5	20.9	26.1	18
	1/4	KQGH08-02S			28.5	22.5			18
	3/8	KQGH08-03S			24	17.7			14
ø10	1/4	KQGH10-02S	17	17	35.5	29.5	23	41.5	29
	3/8	KQGH10-03S			31	24.7			29
ø12	3/8	KQGH12-03S	19	19	32.8	26.5	24.8	58.3	31
	1/2	KQGH12-04S	22			24.6			31

* Reference dimensions after installation of R thread
 Note: Figures shown when using JEP tubing

In case of M5)

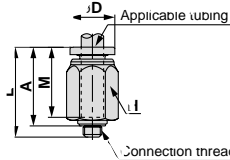

In case of R)

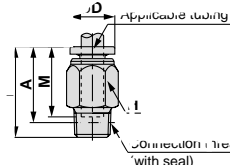

Hexagon Socket Head Male Connector KQGS



Applicable tubing O.D. (mm)	Connection thread R	Model	H (width across flats)	øD	L	A*	M	Effective area (mm ²) ^{Note 1)}	Weight (g)	
ø4	M5	KQGS04-M5	2	10	25	22	18	4	5.3	
	1/8	KQGS04-01S	3			21		4.1	5.3	
ø6	M5	KQGS06-M5	2	12	25.8	22.8	18.8	4	12	
	1/8	KQGS06-01S	4			21.8		9.9	12	
	1/4	KQGS06-02S				19.8		10	20	
ø8	1/8	KQGS08-01S	5	14	30.5	26.5	20.9	17.2	7	
	1/4	KQGS08-02S	6			28.5			22.5	8
	3/8	KQGS08-03S				30.1			23.8	15
ø10	1/4	KQGS10-02S	8	17	35.5	29.5	23	39	28	
	3/8	KQGS10-03S				31			24.7	29
ø12	3/8	KQGS12-03S	10	19	32.8	26.5	24.8	60	30	
	1/2	KQGS12-04S				22			24.6	34

* Reference dimensions after installation of R thread
 Note: Figures shown when using JEP tubing

In case of M5)

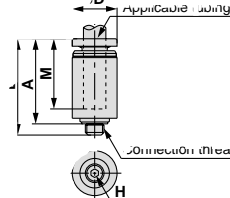

In case of R)

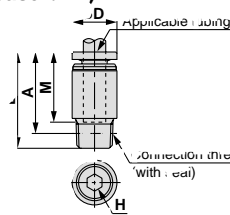

Straight Union KQGH



Applicable tubing O.D. (mm)	Model	øD	L	M	Effective area (mm ²) ^{Note 1)}	Weight (g)
ø4	KQGH04-00	11	37	18	5.6	5
ø6	KQGH06-00	13	38	18.5	13.1	22
ø8	KQGH08-00	15	42.8	20.9	26.1	31
ø10	KQGH10-00	19	47	23	41.5	54
ø12	KQGH12-00	21	50.6	24.8	58.3	66

Note: Figures shown when using JEP tubing

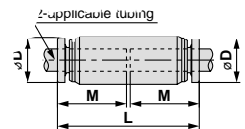

Male Elbow: KQGL



Applicable tubing O.D. (mm)	Connection thread R	Model	H (width across flats)	øD	L1	L2	A*	M	Effective area (mm ²) ^{Note 1)}	Weight (g)
ø4	M5	KQGL04-M5	10	10.6	20.5	16	18.3	18	3.5	5
	1/8	KQGL04-01S				19.5	20.8		4.2	10
ø6	M5	KQGL06-M5	12	13	22.1	17	20.5	18.8	3.5	25
	1/8	KQGL06-01S				20.5	23		9	26
	1/4	KQGL06-02S				14	24.5		25	35
ø8	1/8	KQGL08-01S	14	15	24.9	21.9	25.4	20.9	21.6	37
	1/4	KQGL08-02S				25.9	27.4			35
	3/8	KQGL08-03S				27.9	29.1			36
ø10	1/4	KQGL10-02S	17	18	27.8	27.7	30.7	23	35.2	69
	3/8	KQGL10-03S				29.7	32.4			73
ø12	3/8	KQGL12-03S	19	20.8	31.3	30.7	35.1	24.8	50.2	34

In case of M5)

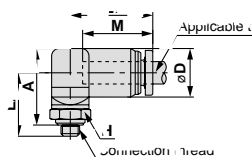

In case of R)

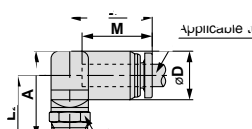

Dimensions

Union Elbow KQGL



Applicable tubing O.D. (mm)	Model	øD	L	A	Q ₁	Q ₂	M	øN	Effective area (mm ²) ^{Note 1)}	Weight (g)
ø4	KQGL04-00	10.6	20.6	27.3	2.3	3.7	18	3.2	4.2	21
ø6	KQGL06-00	13	22.4	28.9	3.5	3.5	18.8	4.2	9	32
ø8	KQGL08-00	15	25.5	35.1						
ø10	KQGL10-00	18	28.6	38.2	5	6.4	23	4.2	35.2	76
ø12	KQGL12-00	20.8	31.4	41.8	6.4	6.4	24.8		50.2	108

Note: Figures shown when using JEP tubing

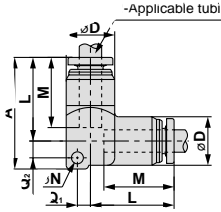

Male Branch Tee: KQGT



Applicable tubing O.D. (mm)	Connection thread R	Model	H (width across flats)	øD	L ₁	L ₂	A*	M	Effective area (mm ²) ^{Note 1)}	Weight (g)
ø4	M5	KQGT04-M5	10	10.6	20.5	18	23.1	18	4.5	26
	1/8	KQGT04-01S				21.5	25.6		6	27
ø6	M5	KQGT06-M5		13	22.1	19	25	18.8	4.5	39
	1/8	KQGT06-01S				22.5	27.5		11	41
ø8	1/4	KQGT06-02S	14	15	24.9	26.5	29.5	20.9	26.3	50
	1/8	KQGT08-01S	12			23.9	30.7			21
	1/4	KQGT08-02S	14			27.9	32.7			21
ø10	3/8	KQGT08-03S		18	27.8	29.9	34.4	23	40.8	33
	1/4	KQGT10-02S	17			29.7	35.7			97
	3/8	KQGT10-03S				31.7	37.4			101
ø12	3/8	KQGT12-03S		20.8	31.3	32.7	39.5	24.8	57.2	105
	1/2	KQGT12-04S	22			36.7	41.6			109

Note: Reference dimensions after installation of R thread. Note: Figures shown when using JEP tubing

In case of M5)

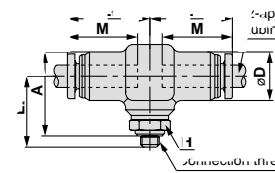

In case of R)

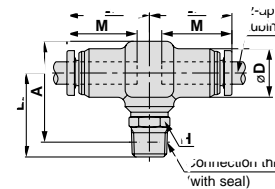

Union Tee: KQGT



Applicable tubing O.D. (mm)	Model	øD	L	A	Q	M	øN	Effective area (mm ²) ^{Note 1)}	Weight (g)
ø4	KQGT04-00	10.6	20.6	28.7	4.1	18	3.2	6.4	28
ø6	KQGT06-00	13	22.4	31.4	4.9	18.8		10.6	42
ø8	KQGT08-00	15	25.5	36.3	6.1	20.9		25.6	57
ø10	KQGT10-00	18	28.6	40.6	7.1	23	4.2	40	95
ø12	KQGT12-00	20.8	31.4	44.5	8.1	24.8		57.4	129

Note: Figures shown when using JEP tubing

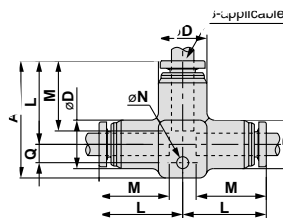

Union 'Y' KQGU



Applicable tubing O.D. (mm)	Model	øD	W	L ₁	L ₂	P	M	øN	Effective area (mm ²) ^{Note 1)}	Weight (g)
ø4	KQGU04-00	10.6	21.2	41	16.8	10.6	18	3.2	2.9	35
ø6	KQGU06-00	13	26	42.9	17	13	18.8		7.4	54
ø8	KQGU08-00	15	30	47.7	18.7	15	20.9		17.9	75
ø10	KQGU10-00	18	36	52.8	20.5	18	23	4.2	28	114
ø12	KQGU12-00	20.8	41.6	57.8	21.9	21	24.8		40.2	155

Note: Figures shown when using JEP tubing

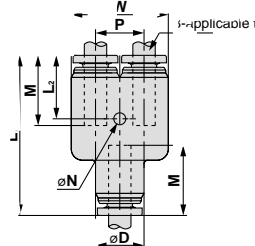

Bulkhead Union KQGE



Applicable tubing O.D. (mm)	Model	T (M)	H (width across flats)	L	Mounting hole	M	Effective area (mm ²) ^{Note 1)}	Weight (g)
ø4	KQGE04-00	M12X1	14	37	13	18	5.6	21
ø6	KQGE06-00	M14X1	17	38	15	18.5	10.4	29
ø8	KQGE08-00	M16X1	19	42.8	17	20.9	26.1	40
ø10	KQGE10-00	M20X1	24	47	21	23	41.5	71

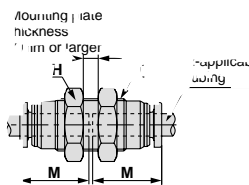





Series KQG

Safety Instructions

The following safety instructions are intended to prevent a hazardous situation and/or equipment damage. The instructions indicate the level of potential hazard by labels "Caution", "Warning" or "Danger". To ensure safety, please observe all safety practices including ISO 4414 ^{Note 1} and JIS B 3370 ^{Note 2}.

 **Caution** : Operator error could result in injury or equipment damage.

 **Warning** : Operator error could result in serious injury or loss of life.

 **Danger** : In extreme conditions, there is a possible result of serious injury or loss of life.

Note 1) ISO 4414: Pneumatic fluid power - General rules relating to systems

Note 2) JIS B 3370: General Rules for Pneumatic Equipment

Warning

1. The compatibility of pneumatic equipment is the responsibility of the person who designs the pneumatic system or decides its specifications.

Since the products specified here are used in various operating conditions, their compatibility with a specific pneumatic system must be based on specifications, post analysis and/or tests to meet a specific requirement. The expected performance and safety assurance is the responsibility of the person who determines the compatibility of the system. This person should continuously review the suitability of all specified items by referring to the latest information in the catalogue and by taking into consideration the possibility of equipment failure when configuring the system.

2. Only trained personnel should operate pneumatic machinery and equipment.

Compressed air can be dangerous if an operator is unfamiliar with it. Assembly, handling or repair of pneumatic systems should be performed by trained and experienced operators.

3. Do not service machinery/equipment or attempt to remove components until the safety of the worker is confirmed.

1. Inspection and maintenance of machinery/equipment should only be performed once measures to prevent falling or runaway of the driver objects have been confirmed.
2. When equipment is to be removed, confirm that all safety precautions have been followed. Cut the supply pressure for this equipment and exhaust all residual compressed air in the system.
3. Before restarting any machinery/equipment exercise caution to prevent quick extension of a cylinder piston rod, etc.

4. Contact SMC if the product will be used in any of the following conditions:

1. Conditions and environments beyond the given specifications, or if product is used outdoors.
2. Installation on equipment in conjunction with atomic energy, railway, air navigation, vehicles, medical equipment, food and beverages, recreation equipment, emergency stop circuits, clutch and brake circuits in press applications, or safety equipment.
3. An application which has the possibility of having a negative affect on people, property, or animals, requiring special safety analysis.



Series KQG

Specific Product Precautions 1

Be sure to read before handling. Refer to page 4 for safety instructions.

Selection

⚠ Caution

1. Do not use in locations where the connecting threads and tubing connection will slide or rotate. The connecting threads and tubing connection will come apart under these conditions.
2. Use tubing at or above the minimum bending radius. Using below the minimum bending radius can cause breakage or flattening of the tube.
3. Consult with SMC regarding fluids other than air, water and nitrogen gas.
4. In case of liquid fluids, keep surge pressure at or below the maximum operating pressure. If the surge pressure exceeds the maximum operating pressure, damage to the fittings and tubing may occur.

Mounting

⚠ Caution

1. Before mounting, please confirm that the model, size, etc. are correct. In addition, please confirm that there are no blemishes, nicks or cracks in the product.
2. When tubing is connected, consider factors such as changes in the tubing length due to pressure, and give adequate space.
3. Mount so that the fittings and tubing are not subjected to strain or moment loads. This can cause damage to the fittings and flattening, bursting or disconnection of the tubing, etc.
4. Mount so that tubing is not damaged due to tangling and abrasion. This can cause flattening, bursting or disconnection of the tubing, etc.

Installation of Threads

⚠ Caution

1. For M5
Tighten the screw within 1.0 to 1.5 N·m of the proper tightening torque. As a guide, after tightening by hand, tighten approximately 1/6 turn further using a tightening tool. Excessive tightening can cause air leakage due to thread damage or deformation of the gasket, etc. Insufficient tightening can cause loose threads and air leakage, etc.
2. Taper threads
When installing, tighten with the proper torque shown in the table below. As a rule, this corresponds to two or three turns with a tool after being tightened by hand.

Connection thread size	Proper tightening torque N·m
R 1/8	7 to 9
R 1/4	12 to 14
R 3/8	22 to 24
R 1/2	28 to 30

Installation of Threads

⚠ Caution

3. Tightening tools
Tighten with an appropriate wrench using the hexagon wrench flats on the body.
Tighten by placing an appropriate wrench firmly against the fitting body. Position the wrench on the base as close as possible to the threads. If the wrench size is not correct, the fitting body may be damaged.

Installation and Removal of Tubing

⚠ Caution

1. Installation of tubing
 - 1) Using tube cutters TK-1, 2 or 3, take a tube having no flaws on its periphery and cut it off at a right angle. Do not use pinchers, nippers or scissors, etc. The tubing might be cut diagonally or flattened, making installation impossible or causing problems such as disconnection and leakage.
 - 2) Hold the tubing and slowly insert it all the way into the fitting.
 - 3) After inserting the tubing, pull on it lightly to confirm that it will not come out. If it is not securely installed all the way into the fitting, problems such as leakage or disconnection of the tubing can occur.
 - 4) Grease is not used therefore, a greater insertion force is required when the tubing is installed. In particular, polyurethane tubing may fold when inserted due to its softness. Hold the end of the tubing, and insert it all the way slowly and securely. Refer to dimension "M" in the dimension drawings for guidance on the insertion depth of tubing.
2. Removal of tubing
 - 1) Sufficiently depress the release bushing and tubing, making sure to apply even pressure around the release bushing.
 - 2) Pull out the tubing while depressing the release bushing so that it does not pop out. If the release bushing is not depressed sufficiently, there will be an increased bite on the tubing and it will become more difficult to pull out.
 - 3) When the removed tubing is reused, first cut off the section of the tubing which has been clamped.
Reusing the clamped portion of the tubing can cause problems such as leakage, difficulties in removal, etc.
In addition, for tubing used at a high temperature or for an extended period of time, there is a possibility that it will not fit into a one-touch fitting again due to an enlarged O.D. dispose of the tubing and replace it with a new one.



Series KQG

Specific Product Precautions 2

Be sure to read before handling. Refer to page 4 for safety instructions.

Operating Environment

Warning

1. Do not use in environments or locations where there is a danger of damage to the fittings and tubing.
For fitting and tubing materials, refer to specifications and construction drawings, etc.
2. Do not operate in locations where vibration or impact occurs because this can cause leakage, damage to fittings, etc. Please contact SMC regarding use in these environments.

Maintenance

Caution

1. Pre-maintenance inspection
When the product is removed, turn off the power, cut off the supply pressure, and confirm that fluid in the piping has been discharged.
2. During regular maintenance, check for the following and replace any components as necessary.
 - a) Scratches, gouges, abrasion, corrosion
 - b) Leakage
 - c) Flattening or distortion of tubing
 - d) Hardening, deterioration or softness of tubing
3. Do not repair the fittings or patch the tubing for reuse.

Precautions on Use of Other Tubing Brands

Caution

1. Our product warranty is not valid if tubing brands other than SMC are used.

SMC CORPORATION (Europe)

Austria	☎ +43 226262280	www.smc.at	office@smc.at	Lithuania	☎ +370 2651602		
Belgium	☎ +32 (0)33551464	www.smc-pneumatics.be	post@smc-pneumatics.be	Netherlands	☎ +31 (0)205318888	www.smc-pneumatics.nl	info@smc-pneumatics.nl
Bulgaria	☎ +359 2 9744492	www.smc.bg	office@smc.bg	Norway	☎ +47 67129020	www.smc-norge.no	post@smc-norge.no
Croatia	☎ +385 1 377 66 74	www.smceu.com	office@smc.hr	Poland	☎ +48 225485085	www.smc.pl	office@smc.pl
Czech Republic	☎ +42 0541424611	www.smc.cz	office@smc.cz	Portugal	☎ +351 226108922	www.smces.es	postpt@smc.smces.es
Denmark	☎ +45 70252900	www.smc.dk	smc@smc-pneumatik.dk	Romania	☎ +40 213205111	www.smcromania.ro	smccadm@canad.ro
Estonia	☎ +372 (0)6593540	www.smc-pneumatics.ee	smc@smc-pneumatics.ee	Russia	☎ +812 1185445	www.smc-pneumatik.ru	smcfa@peterlink.ru
Finland	☎ +358 (0)9859580	www.smc.fi	smc@smc-pneumatics.ee	Slovakia	☎ +421 244456725	www.smc.sk	office@smc.sk
France	☎ +33 (0)164761000	www.smc-france.fr	smc@smc-pneumatics.ee	Slovenia	☎ +386 73885249	www.smc-ind-avtom.si	office@smc-ind-avtom.si
Germany	☎ +49 (0)61034020	www.smc-pneumatik.de	contact@smc-france.fr	Spain	☎ +34 945184100	www.smces.es	post@smc.smces.es
Greece	☎ +30 (0)13426076	www.smceu.com	info@smc-pneumatik.de	Sweden	☎ +46 (0)86031200	www.smc.nu	post@smc-pneumatics.se
Hungary	☎ +36 13711343	www.smc-automation.hu	parianos@hol.gr	Switzerland	☎ +41 (0)523963131	www.smc.ch	info@smc.ch
Ireland	☎ +353 (0)14039000	www.smc-pneumatics.ie	office@smc-automation.hu	Turkey	☎ +90 (0)2122211512	www.entek.com.tr	smc-entek@entek.com.tr
Italy	☎ +39 (0)292711	www.smcitalia.it	sales@smc-pneumatics.ie	UK	☎ +44 (0)8001382930	www.smc-pneumatics.co.uk	sales@smc-pneumatics.co.uk
Latvia	☎ +371 (0)7779474	www.smc.lv	mailbox@smcitalia.it				
			info@smc.lv				