

# Self-seal Fittings Series *KC*

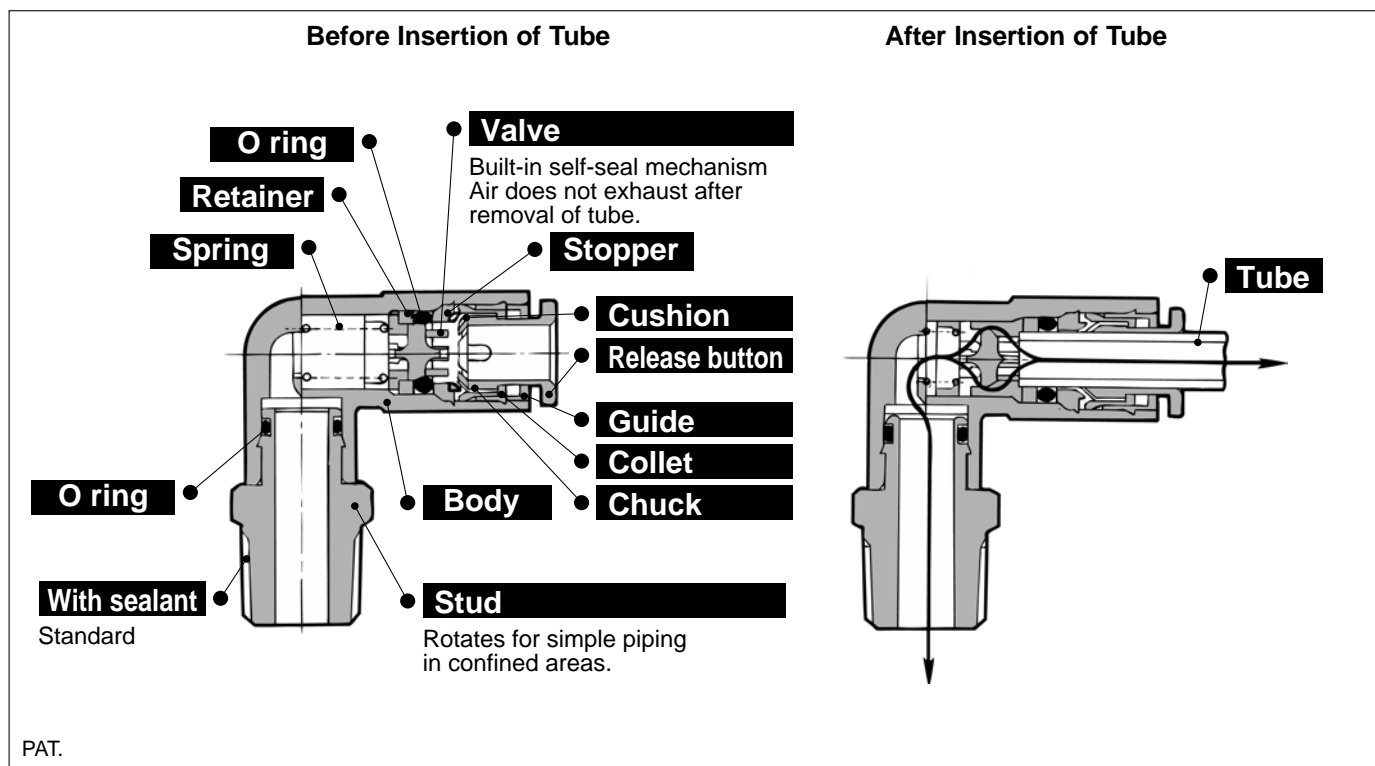

**One-touch fitting (With built-in self-seal mechanism) to prevent air exhaust when removing tube.**

**Best for multiple use areas when pressure cannot be shut down.**

**10 styles are available.**

**Electroless nickel plated for copper-free applications.**



## Applicable Tubing











Tube material	Nylon, Soft nylon, Polyurethane
Tube O.D.	ø4, ø6, ø8, ø10, ø12

## Specifications

Operating fluid	Air	
Max. operating pressure	1.0MPa	
Proof pressure	3.0MPa	
Ambient and fluid temperature	-5 to 60°C (No freezing)	
Thread	Thread portion	JIB B0203 (Taper pipe thread)
	Nut	JIB B0211 Class 2 (Metric fine thread)
Sealant (Thread portion)	With sealant (Standard)	
Copper-free application	All brass parts with electroless nickel plated	

## Component Materials

Body	C3604BD, PBT
Stud	C3604BD (Thread portion)
Chuck, Spring	Stainless Steel (SUS304)
Guide	SUS304, C3604BD, Polyacetal (POM)
Collet, Release button	Polyacetal (POM)
Valve, Retainer	Polyacetal (POM)
Stopper	C3604BD, Polyacetal (POM)
Packing, O ring	NBR

Model			
<b>Male connector</b> <b>KCH</b> P.2.1-62 	Used to pipe in the same direction from female threaded portion.	<b>Straight union</b> <b>KCH</b> P.2.1-63 	Used to connect tubes in the same direction. One of two ports has a self-seal function.
<b>Male elbow</b> <b>KCL</b> P.2.1-62 	Used to pipe in right angles to female threaded portion. Most common style.	<b>Straight plug for frequent use</b> <b>KCH</b> P.2.1-63 	Used to connect a self-seal fitting and a tube in the same direction. It can save the tube cutting labor in the case of frequent tube installation and removal.
<b>Union tee</b> <b>KCT</b> P.2.1-62 	Used to connect tubes in both 90° directions.	<b>Elbow plug for frequent use</b> <b>KCL</b> P.2.1-64 	Used to pipe a tube at right angles to a self-seal fitting. It can save the tube cutting labor in the case of frequent tube installation and removal.
<b>Union "Y"</b> <b>KCU</b> P.2.1-62 	Used to connect tubes in the same direction. 2 branched ports has a self-seal function.		
<b>Check adaptor</b> <b>KCJ</b> P.2.1-63 	Used to add the self-seal mechanism to the usual One-touch fittings, Series KQ.		
<b>Bulkhead union</b> <b>KCE</b> P.2.1-63 	Used for junction connection of tubes for installation on a panel. One of two ports has a self-seal function.		
<b>Bulkhead female union</b> <b>KCE</b> P.2.1-63 	Used for transit connection of a tube and a male screw for installation on a panel.		

- K**
- M**
- H**
- D**
- MS**
- T**
- LQ**
- Clean Room

## ⚠ Precautions

Be sure to read before handling. Refer to p.0-26 and 0-27 for Safety Instructions and common precautions on the products mentioned in this catalogue, and refer to p.2.0-7 and 2.0-8 for more detailed precautions of every series.

### Tube Insertion and Removal from Self-seal Fitting

#### ⚠ Caution

##### ● Installing Tube

- ① Cut the tube perpendicularly, taking care not to damage the outside surface. (Use tube cutter TK-1, 2 or 3. Do not cut the tube with cutting pliers, nippers, scissors, etc.) Flat or angled cuts will make it difficult to connect to fittings or, if connected, tube will release or air leakage will occur.
- ② Grasp the tube, then slowly push it until it comes to a stop.
- ③ Pull it back gently to make sure that it has a positive seal.  
Incomplete installation may cause air leakage or tube release.

##### ● Removing Tube

- ① Push the release button into the fitting.  
The button should be pushed evenly.
- ② Pull out the tube while keeping the release button depressed. (If the release button is not held down, the tube cannot be withdrawn.)
- ③ To reuse the tubing, cut off the previously lodged portion of the tube.  
If using tubing without cutting the damaged portion off, it may cause the air leakage or make it difficult to release the tube.

### The Number of Insertions and Removals from Self-seal Fitting

#### ⚠ Caution

- ① The number of insertions and removals as a rough guide is as follows.
  - Tube.....300 times
  - Metal stem.....1000 times

### Installation of Self-seal Fitting

#### ⚠ Caution

- ① The fitting should be installed (Installation of R (PT) thread portion) by screwing with a spanner at the hexagonal portion of the body.  
The position of spanner should be a root as close as possible to R (PT) thread. Use the spanner corresponding to the size of hexagonal portion, or hexagonal portion may be deformed.

### Tightening the thread portion of an M5 size fitting

#### ⚠ Caution

- ① First, tighten it by hand, then give it an additional 1/6 turn with a wrench.  
Excessive tightening may damage the threaded portion or deform the gasket to cause air leakage. Insufficient tightening may leave the thread loosened or cause air leakage.

### Distinction of plug and applicable fitting

#### ⚠ Caution

- ① The applicable fitting should be chosen depending on the style of plug.
  - Check adaptor  
How to use: Use it for addition of self-seal mechanism to a standard One-touch fitting series KQ.  
Self-seal fittings with check adaptor are not available. It causes the air leakage.



- Elbow plug for frequent use, straight plug for frequent use.  
How to use: For use in the case of frequent tube installation and removing, tube cutting labor can be saved. These plugs are not available for a standard One-touch fittings Series KQ.  
If trying to install the plug into a KQ, plug will jump out of the fitting. Note the exclusive marking for self-seal fittings before use.

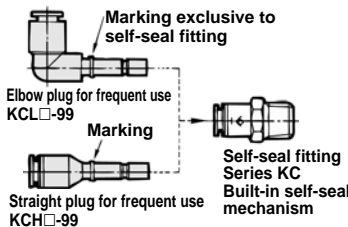

### Tube Insertion and Removal under a pressurized condition

#### ⚠ Caution

- ① When inserting/removing of the tube is difficult under a pressurized condition, it should be inserted or removed by lowering the pressure or after fully exhausting.

## Male connector: **KCH**

<M5>



<R(PT)>



Tube O.D. (mm)	Thread R(PT)	Part No.	H (Hex.)	L	A*	M	Effective area (mm <sup>2</sup> )		Weight (g)
							Nylon	Urethane	
4	M5	KCH04-M5	9.8	30.8	27.3	18	2.1	2.1	8
	1/8	KCH04-01S	10	26.1	22.1		2.6	2.6	
6	M5	KCH06-M5	11.8	32.4	28.9	19.5	2.4	2.4	10
	1/8	KCH06-01S	12	37.4	33.4		6.8	6.8	16
	1/4	KCH06-02S	14	28.9	22.9				14
8	1/8	KCH08-01S	14	42.4	38.4	21.5	16.2	13.1	20
	1/4	KCH08-02S		45.7	39.7				27
	3/8	KCH08-03S		17	34				27.5
10	1/4	KCH10-02S	17	50.5	44.5	24	25.6	20.4	34
	3/8	KCH10-03S		51.5	45				43
12	3/8	KCH12-03S	19	54.2	47.7	25.5	35.4	30.4	48
	1/2	KCH12-04S	22	41.6	33.6				41

\*Reference dimensions after R(PT) installation.

<M5>

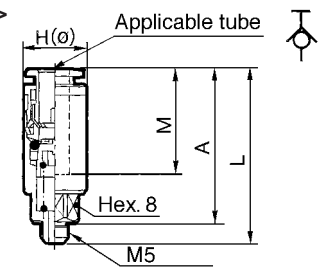

<R(PT)>

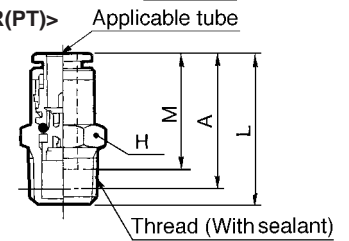

## Male elbow: **KCL**



Tube O.D. (mm)	Thread R(PT)	Part No.	H (Hex.)	øD <sup>(1)</sup>	øD <sub>2</sub>	L <sub>1</sub>	L <sub>2</sub>	A*	M	Effective area (mm <sup>2</sup> )		Weight (g)	
										Nylon	Urethane		
4	M5	KCL04-M5	8	10.4	8	25.3	16.7	18.4	18	1.9	1.9	6	
	1/8	KCL04-01S	10		10	23	24.2	2.3		2.3	11		
6	M5	KCL06-M5	8	12.8	8	26.8	17.4	20.3	19.5	2.2	2.2	7	
	1/8	KCL06-01S	12		12	28	25.1	27.5		6.2	6.2	13	
8	1/8	KCL08-01S	14	15.2	14	34.1	27.1	30.7	21.5	13.0	10.5	16	
	1/4	KCL08-02S					31.1	34.2				24	37
	3/8	KCL08-03S					17	31.1				34.2	24
10	1/4	KCL10-02S	17	18.5	17	38	33.9	37.2	24	19.5	16.5	29	
	3/8	KCL10-03S					35.9	38.7				38	
12	3/8	KCL12-03S	22	20.9	20.9	40.7	40.3	44.3	25.5	24.8	21.3	63	
	1/2	KCL12-04S					43.2	45.7				81	

\*Reference dimensions after R(PT) installation.

Note1) øD<sub>1</sub>: max. diameter

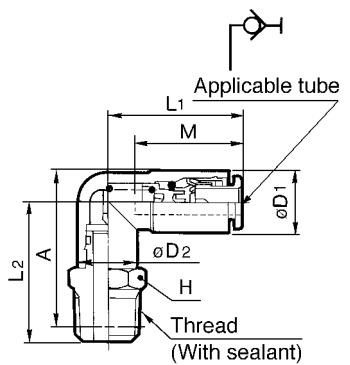

## Union tee: **KCT**



Tube O.D. (mm)	Part No.	øD <sup>(1)</sup>	L	Q	M	Effective area (mm <sup>2</sup> )		Weight (g)
						Nylon	Urethane	
4	KCT04-00	10.4	28.6	5.3	18	2.8	2.8	8
6	KCT06-00	12.8	32.7	6.1	19	7.6	7.6	15
8	KCT08-00	15.2	39.2	7.1	21.5	13.7	11.1	23
10	KCT10-00	18.5	45.5	7.9	24	21.1	19.0	39
12	KCT12-00	20.9	49.2	8.6	25.5	28.3	24.3	52

Note1) øD: max. diameter

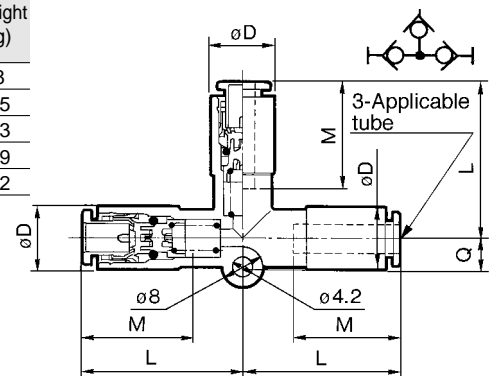

## Union "Y": **KCU**



Tube O.D. (mm)	Part No.	øD <sup>(1)</sup>	L <sub>1</sub>	L <sub>2</sub>	P	Q	M <sub>1</sub>	M <sub>2</sub>	Effective area (mm <sup>2</sup> )		Weight (g)
									Nylon	Urethane	
4	KCU04-00	10.4	43.1	27.3	10.4	10.6	18	16	3.7	3.7	8
6	KCU06-00	12.8	48	31.2	12.8	12.5	19	17	10.0	10.0	14
8	KCU08-00	15.2	57.6	38.9	15.2	14.7	21.5	18.5	21.7	15.1	22
10	KCU10-00	18.5	65.2	44.9	18.5	17.1	24	21	33.3	25.6	37
12	KCU12-00	20.9	70.1	48.8	20.9	19.1	25.5	22	48.9	38.7	49

Note1) øD: max. diameter

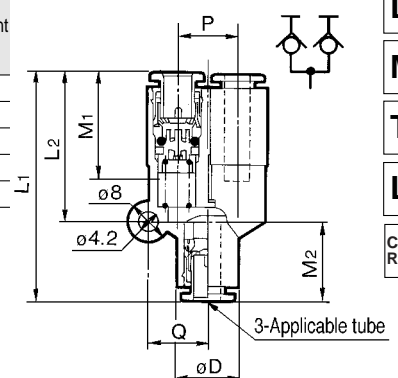

K□

M□

H□

D□

MS

T□

LQ

Clean Room

# Series KC

## Check adaptor: KCJ



Tube O.D. (mm)	Part No.	ød	øD <sup>(1)</sup>	L	A	M	Effective area (mm <sup>2</sup> )		Weight (g)
							Nylon	Urethane	
4	KCJ04-99	4	9.8	49.5	33.5	18	2.6	2.6	9
6	KCJ06-99	6	11.8	54	37	19	6.8	6.8	13
8	KCJ08-99	8	14	61	42.5	21.5	16.2	13.1	20
10	KCJ10-99	10	17	70.4	49.4	24	25.6	20.4	33
12	KCJ12-99	12	19	74.4	52.4	25.5	35.4	30.4	43

Note1) øD: max. diameter

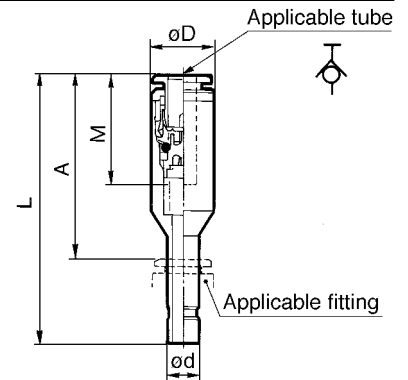

## Bulkhead union: KCE



Tube O.D. (mm)	Part No.	T (M)	H (Hex.)	L	Mounting hole	M1	M2	Effective area (mm <sup>2</sup> )		Weight (g)
								Nylon	Urethane	
4	KCE04-00	M12 X 1	14	42	13	18	16	2.6	2.6	21
6	KCE06-00	M14 X 1	17	45.5	15	19	17	6.8	6.8	30
8	KCE08-00	M16 X 1	19	52.5	17	21.5	18.5	16.2	13.1	39
10	KCE10-00	M20 X 1	24	59.5	21	24	21	25.6	20.4	84
12	KCE12-00	M22 X 1	27	63.2	23	25.5	22	35.4	30.4	115

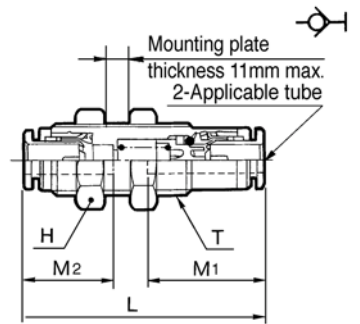

## Bulkhead female union: KCE



Tube O.D. (mm)	Thread Rc (PT)	Part No.	T (M)	H1 (Hex.)	H2 (Hex.)	L1	L2	Mounting hole	M	Effective area (mm <sup>2</sup> )		Weight (g)
										Nylon	Urethane	
4	1/4	KCE04-02	M12 X 1	17	14	40.5	14.7	13	18	2.6	2.6	32
6	1/4	KCE06-02	M14 X 1	17	17	42.7	14.7	15	19	6.8	6.8	36
8	3/8	KCE08-03	M16 X 1	19	19	49.4	15	17	21.5	16.2	13.1	42
10	3/8	KCE10-03	M20 X 1	22	24	53.9	14.2	21	24	25.6	20.4	79
12	3/8	KCE12-03	M22 X 1	24	27	56.1	13.7	23	25.5	35.4	30.4	105

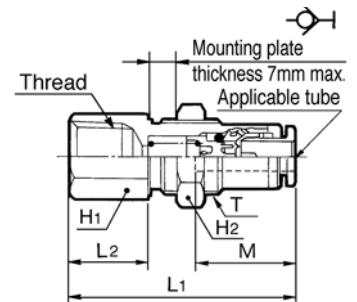

## Straight union: KCH



Tube O.D. (mm)	Part No.	øD <sup>(1)</sup>	L	M1	M2	Effective area (mm <sup>2</sup> )		Weight (g)
						Nylon	Urethane	
4	KCH04-00	10.4	42.1	18	16	2.6	2.6	5
6	KCH06-00	12.8	45.8	19	17	6.8	6.8	7
8	KCH08-00	15.2	52.8	21.5	18.5	16.2	13.1	10
10	KCH10-00	18.5	59.8	24	21	25.6	20.4	18
12	KCH12-00	20.9	63.5	25.5	22	35.4	30.4	24

Note1) øD: max. diameter

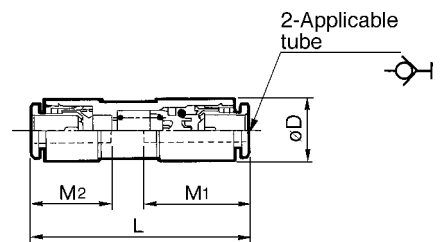

## Straight plug for frequent use: KCH



Tube O.D. (mm)	Part No.	ød	øD <sup>(1)</sup>	L	A	M	Effective area (mm <sup>2</sup> )		Weight (g)
							Nylon	Urethane	
4	KCH04-99	4	9.8	40.6	22.6	16	5.6	4	5
6	KCH06-99	6	11.8	43.1	24.1	17	13.1	10.4	8
8	KCH08-99	8	14	46.7	25.2	18.5	26.1	18.0	11
10	KCH10-99	10	17	52.6	28.6	21	41.5	29.5	18
12	KCH12-99	12	19	54.9	29.4	22	58.3	46.1	24

Note1) øD: max. diameter

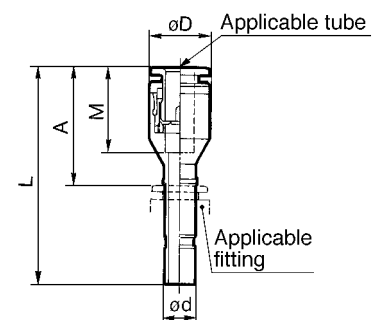

## Elbow plug for frequent use: **KCL**

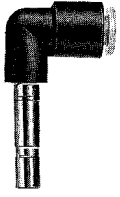

Tube O.D. (mm)	Part No.	ød	øD <sub>1</sub> <sup>(1)</sup>	øD <sub>2</sub> <sup>(1)</sup>	L <sub>1</sub>	L <sub>2</sub>	A	M	Effective area (mm <sup>2</sup> )		Weight (g)
									Nylon	Urethane	
4	<b>KCL04-99</b>	4	10.4	10	18	34.3	22.6	16	4.2	4.2	7
6	<b>KCL06-99</b>	6	12.8	10	20	36.5	24.1	17	11.4	9.0	8
8	<b>KCL08-99</b>	8	15.2	12	23	40.3	25.2	18.5	21.6	14.9	12
10	<b>KCL10-99</b>	10	18.5	17	26.5	44.3	28.6	21	35.2	25.0	25
12	<b>KCL12-99</b>	12	20.9	17	28.5	46.8	29.4	22	50.2	39.7	30

Note1) øD<sub>1</sub>, øD<sub>2</sub>: max. diameter

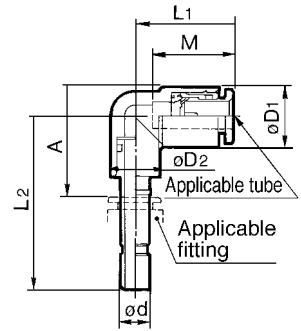

**K** □

**M** □

**H** □

**D** □

**MS**

**T** □

**LQ**

Clean Room